

PHILIPS

Fortimo

LED

Fortimo LED Line 2ft
2200lm 8xx 3R HV4



Datasheet

Fortimo LED Line Gen4

Fortimo LED Line is designed to produce pure white light for general lighting applications with high efficiency levels. The Fortimo LED Line portfolio consists of 2 main ranges of products, which have been differentiated by the number of rows of LEDs on the module. Both ranges feature a variety of different length modules, lumen packages and color temperatures for all the different types of linear luminaires.

Key features and benefits

- State-of-the-art LED module efficiency of up to 186 lm/W
- Long life-time: >50,000 hours
- High color rendering (CRI >80 and >90)
- Excellent color consistency of 3 SDCM
- Choice of color temperatures (3000, 4000 and 5000 K)
- Two module lengths: 1 ft/280 mm or 2 ft/560 mm
- Three lumen packages: 650, 1100, and 2000 lm per foot/280 mm
- LED module range with 1 or 3 rows of LEDs
- Tunable lumen output, efficacy and lifetime
- Push-in connectors enabling automated wiring
- Wide temperature (Tc) range from -40 °C up to +90 °C
- Five year system warranty

May 2017

Ordering data

Commercial product name	EOC	12NC	Box quantity
Fortimo LED Line 2ft 2200lm 830 3R HV4	8718696 901731 00	9290 015 44806	180
Fortimo LED Line 2ft 2200lm 840 3R HV4	8718696 901748 00	9290 015 44906	180
Fortimo LED Line 2ft 2200lm 850 3R HV4	8718696 901755 00	9290 015 45006	180

Drive currents

Parameter	Nominal*	Life**	Max***	Unit
Fortimo LED Line 2ft 2200lm 8xx 3R HV4	198	450	450	mA

Module temperatures

Parameter	Nominal*	Life**	Max***	Unit
T _c (case temperature at T _c point)	40	80	80	°C

* Nominal value at which typical performance is specified

** Value at which life time is specified

*** Maximum value for safe operation, do not operate above this value

Optical characteristics - table per color (CCT)

Fortimo LED Line 2ft 2200lm 830 3R HV4

Parameter	Min	Typ	Max	Unit
Luminous flux	1933	2090	2247	lm
Module efficacy	156	174	191	lm/W
Correlated color temperature (CCT)		3000		K
Color coordinates (CIEx, CIEy)		(0.433, 0.400)		-
Color consistency			3	SDCM
CRI	80			
Radiation angle		120		deg
Photobiological safety			RG1	
Energy efficiency label		A++		
$\Delta u'v'$ at 6000 hours			0.007	

R9=7

Measurement precision $\pm 5\%$ for the flux data and $\pm 6\%$ for the efficacy data. Measurement precision for color coordinates ± 0.005 . Measurement precision for CRI ± 1.5

Operation point	830	lm	lm/W
80% I-nom 158mA	Tc 25 °C	1711	179
	Tc-nom 40 °C	1682	177
	Tc-life 80 °C	1599	170
I-nom 198mA	Tc 25 °C	2121	175
	Tc-nom 40 °C	2090	174
	Tc-life 80 °C	1982	167
I-life 450mA	Tc 25 °C	4567	157
	Tc-nom 40 °C	4488	155
	Tc-life 80 °C	4257	149

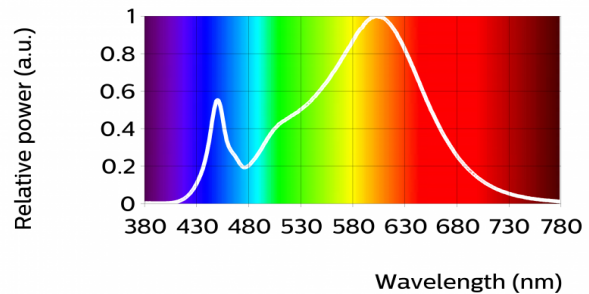

Fortimo LED Line 2ft 2200lm 840 3R HV4

Parameter	Min	Typ	Max	Unit
Luminous flux	2035	2200	2365	lm
Module efficacy	164	183	201	lm/W
Correlated color temperature (CCT)		4000		K
Color coordinates (CIEx, CIEy)		(0.383, 0.375)		-
Color consistency			3	SDCM
CRI	80			
Radiation angle		120		deg
Photobiological safety			RG1	
Energy efficiency label		A++		
$\Delta u'v'$ at 6000 hours			0.007	

R9=6

Measurement precision $\pm 5\%$ for the flux data and $\pm 6\%$ for the efficacy data. Measurement precision for color coordinates ± 0.005 . Measurement precision for CRI ± 1.5

Operation point	840	lm	lm/W
80% I-nom 158mA	Tc 25 °C	1801	1888
	Tc-nom 40 °C	1771	186
	Tc-life 80 °C	1684	179
I-nom 198mA	Tc 25 °C	2232	185
	Tc-nom 40 °C	2200	183
	Tc-life 80 °C	2086	176
I-life 450mA	Tc 25 °C	4810	165
	Tc-nom 40 °C	4727	163
	Tc-life 80 °C	4484	156

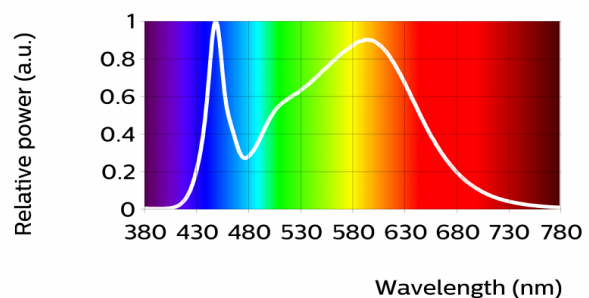

Fortimo LED Line 2ft 2200lm 850 3R HV4

Parameter	Min	Typ	Max	Unit
Luminous flux	2055	2222	2389	lm
Module efficacy	166	185	203	lm/W
Correlated color temperature (CCT)		5000		K
Color coordinates (CIEx, CIEy)		(0.345, 0.352)		-
Color consistency			3	SDCM
CRI	80			
Radiation angle		120		deg
Photobiological safety			RG1	
Energy efficiency label		A++		
$\Delta u'v'$ at 6000 hours			0.007	

R9=8

Measurement precision $\pm 5\%$ for the flux data and $\pm 6\%$ for the efficacy data. Measurement precision for color coordinates ± 0.005 . Measurement precision for CRI ± 1.5

Operation point	850	lm	lm/W
80% I-nom 158mA	Tc 25 °C	1818	190
	Tc-nom 40 °C	1789	188
	Tc-life 80 °C	1700	181
I-nom 198mA	Tc 25 °C	2255	186
	Tc-nom 40 °C	2222	185
	Tc-life 80 °C	2107	177
I-life 450mA	Tc 25 °C	4859	167
	Tc-nom 40 °C	4775	164
	Tc-life 80 °C	4530	158

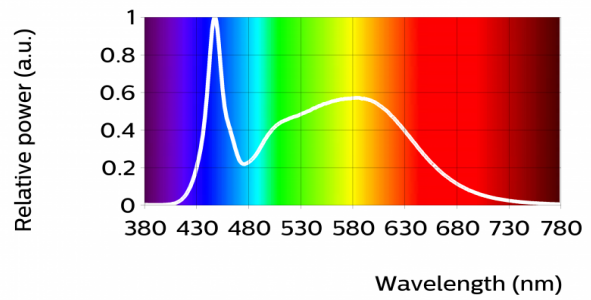

Beam shape

The Philips LED module generates a Lambertian beam shape, which is a pragmatic starting point for OEMs wishing to design secondary optics.

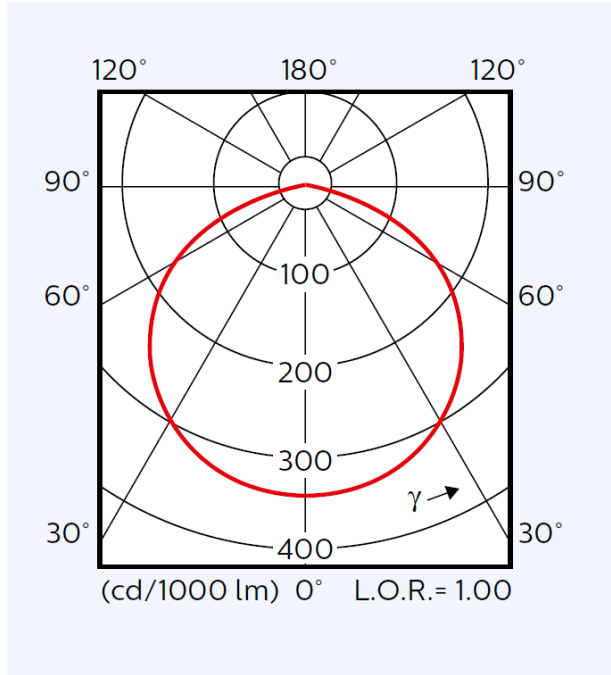

Electrical characteristics

[Fortimo LED Line 2ft 2200lm 830 3R HV4](#)
[Fortimo LED Line 2ft 2200lm 840 3R HV4](#)
[Fortimo LED Line 2ft 2200lm 850 3R HV4](#)

Parameter	Min	Typ	Max	Unit
Forward voltage	58.9	60.9	62.9	V
Power consumption	11.6	12.0	12.4	W
Number of modules in series per chain			4	

Measurement precision for Vf +/- 3%. Measurement precision for power +/- 3.3%
 Specifications stated at Tc-nom and I-nom
 Bins D and I

Tuning information

Flux and efficacy versus current (at Tc nominal)

I [mA]	Flux [%]	Efficacy [%]
450	215	89
296	147	95
237	119	98
198	100	100
178	90	101
158	81	102
138	71	103
119	61	104
99	51	105

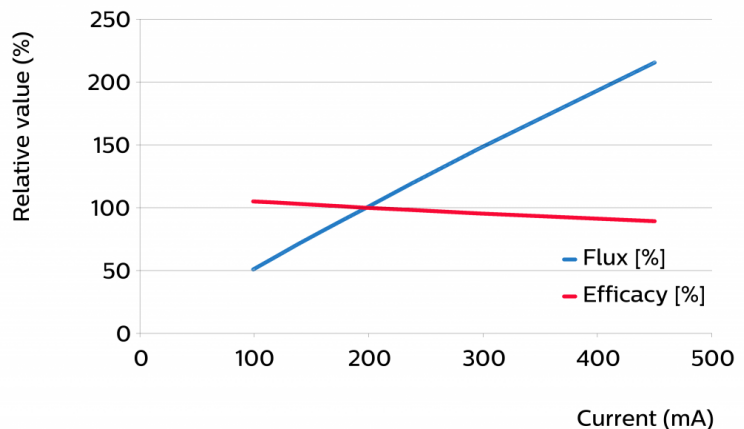

Flux and efficacy versus temperature at Tc (at I nominal)

Tcase [°C]	Flux [%]	Efficacy [%]
80	95	96
40	100	100
25	102	101
0	104	103

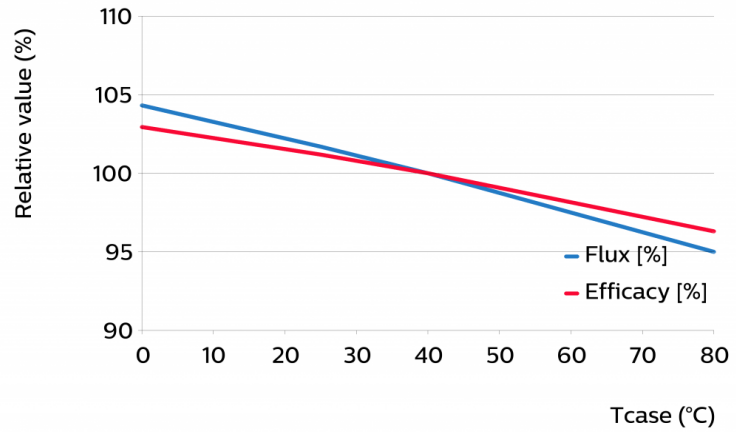

Lumen maintenance

Operation point	Lumen maintenance x 1000 hours	L70			L80			L90		
		B50	B20	B10	B50	B20	B10	B50	B20	B10
80% I-nom 158mA	Tc 25°C	>70	>70	>70	>70	>70	>70	36	35	35
	Tc-nom 40°C	>70	>70	>70	68	66	65	32	31	31
	Tc-life 80°C	>70	70	69	45	44	43	21	21	20
I-nom 198mA	Tc 25°C	>70	>70	>70	>70	>70	>70	36	35	35
	Tc-nom 40°C	>70	>70	>70	68	66	65	32	31	31
	Tc-life 80°C	>70	70	69	45	44	43	21	21	20
I-life 450mA	Tc 25°C	>70	>70	>70	58	56	56	27	27	26
	Tc-nom 40°C	>70	>70	>70	58	56	56	27	27	26
	Tc-life 80°C	61	60	59	38	37	37	18	18	17

Values in the table are based on available LM80 LED data (12000 hours). Lumen maintenance will be updated once additional measurement data becomes available.

Thermal switching table

Calculated number of switches at which the survival rate of the population $\geq 90\%$, at a given ambient temperature and delta T with respect to Tc (where $T_c = T_{\text{ambient}} + \Delta T$)

		Tambient [°C]											
		-40	-30	-20	-10	0	10	20	30	40	50	60	70
delta T [°C] (delta T = Tc - Tambient)	10	> 100 k	> 100 k	> 100 k	> 100 k	> 100 k	> 100 k	> 100 k	> 100 k	> 100 k	> 100 k	> 100 k	> 100 k
	20	> 100 k	> 100 k	> 100 k	> 100 k	> 100 k	> 100 k	> 100 k	> 100 k	> 100 k	> 100 k	> 100 k	X
	30	> 100 k	> 100 k	> 100 k	> 100 k	> 100 k	> 100 k	> 100 k	> 100 k	> 100 k	> 100 k	X	X
	40	> 100 k	> 100 k	> 100 k	> 100 k	> 100 k	> 100 k	> 100 k	> 100 k	X	X	X	X
	50	51k	51k	51k	51k	51k	51k	51k	51k	X	X	X	X
	60	25k	25k	25k	25k	25k	25k	25k	X	X	X	X	X
	70	14k	14k	14k	14k	14k	14k	X	X	X	X	X	X
	80	9k	9k	9k	9k	X	X	X	X	X	X	X	X
	90	5k	5k	5k	X	X	X	X	X	X	X	X	X
	100	4k	4k	X	X	X	X	X	X	X	X	X	X

Lumen maintenance graphs

Lumen maintenance at I-life and Tc-life conditions

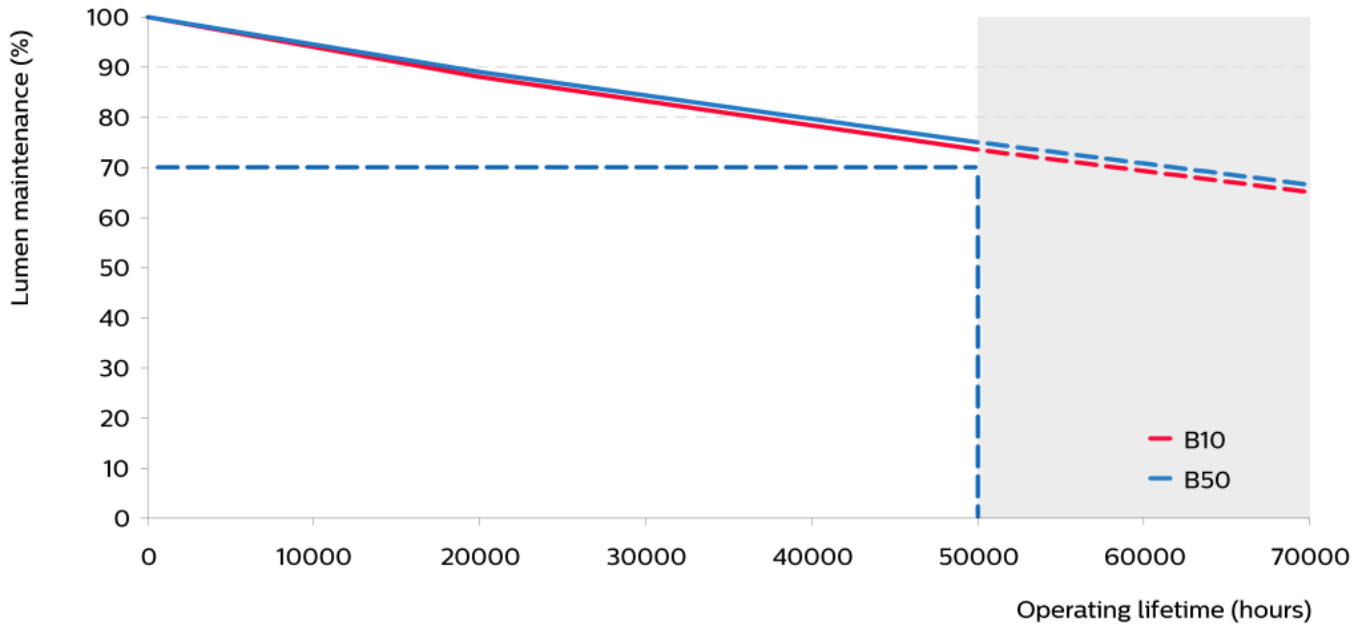

Lumen maintenance for B50 at current I-life conditions

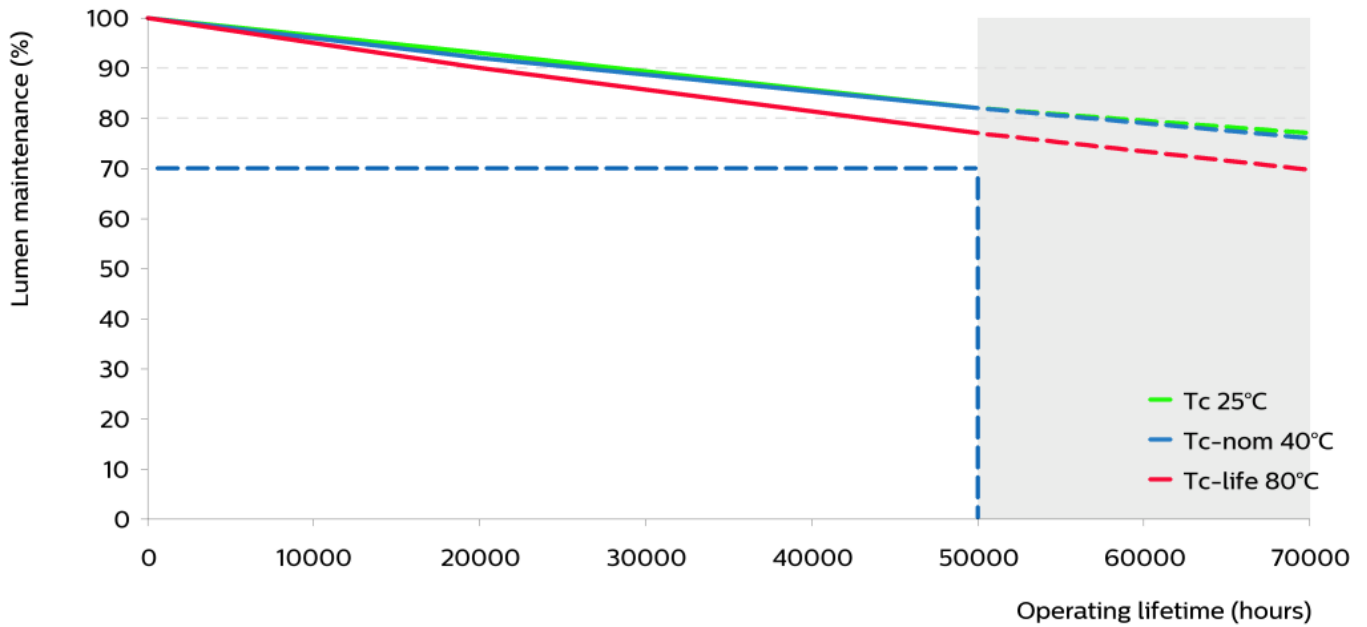

Wiring

Specification item	Value	Unit	Condition
Input wire cross-section	0.33...0.75	mm ²	solid, fused, stranded
	18...22	AWG	solid, fused, stranded
Input wire strip length	7.5...8.5	mm	
Input wire cross-section	0.33...0.5	mm ²	stranded wire
	20...22	AWG	stranded wire
Input wire strip length	7.5...8.5	mm	

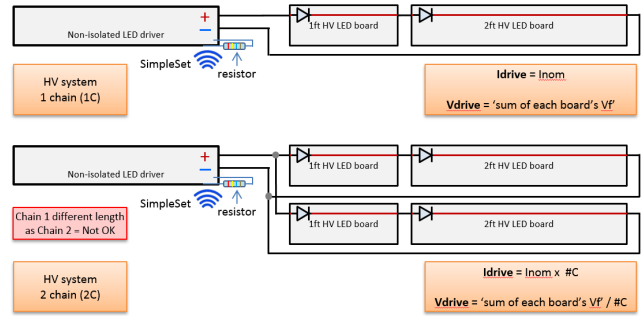
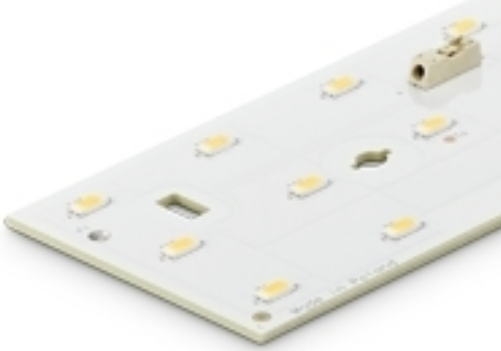

More information in the design-in guide of LED Linear modules.

Mechanical characteristics

Fortimo LED Line 2ft 2200lm 830 3R HV4
 Fortimo LED Line 2ft 2200lm 840 3R HV4
 Fortimo LED Line 2ft 2200lm 850 3R HV4

Parameter	Min	Typ	Max	Unit
Length	565.5	566	566.5	mm
Width	54.5	55	55.5	mm
Height excl. connector	4.19	4.29	4.39	mm
Height incl. connector	5.6	5.8	6	mm
Warpage (IPC-TM-650)			0.75	%

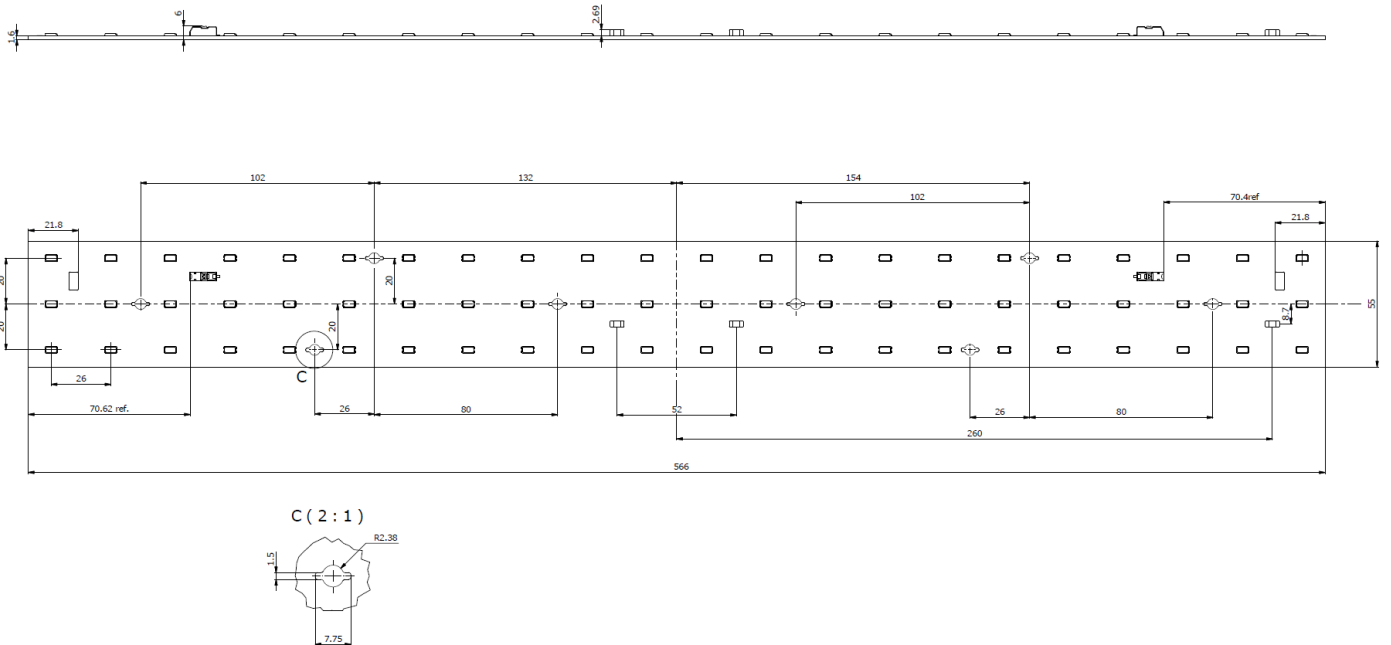

Absolute ratings

Parameter	Min	Typ	Max	Unit
Current through the LED module (I-max)			450	mA
Case temperature (Tc-max)			80	°C
Power at rated Vf-max and I-max			30.7	W
ESD (direct contact)			8	kV
ESD (air)			15	kV
Working voltage			420	V _{dc}
Voltage strength	1840			V _{ac}
Ambient temperature	-40			°C

Application information

Certificates and Standards

IEC/TR 62278:2014

IEC 62384

IEC 62031:2008 (First Edition) + A1:2012 + A2:2014

Relevant clauses of EN 62471:2008 (With IEC/TR 62471-2: 2009 and IEC/TR 62778: 2014)

ENEC+

CE

ENEC

Application

IP rating	No IP-rating
Overheating protection	No protection
Luminaire class	IEC Class I and IEC Class II
Dimming	Yes



© 2017 Philips Lighting Holding B.V. All rights reserved.

This document contains information relating to the Philips Lighting portfolio, intended for companies who may be interested in developing their product offering. Note that the information provided is subject to change. Philips Lighting does not give any representation or warranty as to the accuracy or completeness of the information included herein and shall not be liable for any action in reliance thereon. The information presented in this document is not intended as any commercial offer and does not form part of any quotation or contract.

www.philips.com/technology

05/2017